



GREENSUN SOLAR



POWERWALL LiFePO4 Lithium Iron Phosphate Battery



GreensunSolar

Module Introduction

24V 200AH Wall Mount

Specification	
Model	LFP24-200 Powerwall
Battery Type	LiFePO4(LFP)
Norminal Voltage(V)	24V
Norminal Energy(KWH)	5KWH
Design Life	20Years(25°C /77°F)
Physical	
Dimension(mm)	610*445*200mm
Weight(kg)	59kg
Electrical	
Cycle Life	>6000, 25°C
Max Discharge Voltage(V)	29.2
Max Charge Voltage(V)	29.2
Charge/Discharge Current(A)	50A(Recommended) 100A(Max)
Internal Resistance	≤30mΩ
BMS	
Power Consumption	<2W(Work)<100mw(Sleep)
Monitoring Parameters	System voltage, current, cell voltage, cell temperature, module temperature
SOC	Intelligent algorithm
Communication	CAN/RS-485/RS-232
Operation	
Operating Temperature Range	-10°C-50°C
Transport Storage Temperature Range	-20°C-45°C
Humidity	15%-85%(No Condensing)
Warranty	
Warranty	12 Years



Smart

Each module is equipped with an independent BMS system.



Easy Installation

Just Plug & Play.



Safe

Safe lithium iron phosphate battery cell.



Certifications

TUV UL CE IEC
UN38.3 CEC.



Modular

Modular expansion.



Longer Lifetime

6000 cycles, 20 years design life.



The Battery system is widely used in RESS(Residential Energy Storage System such as solar storage system,UPS). The Powerwall LiFePO4 Battery Pack adopts international advanced lithium iron phosphate battery application technology and BMS control technique.

1.Specification

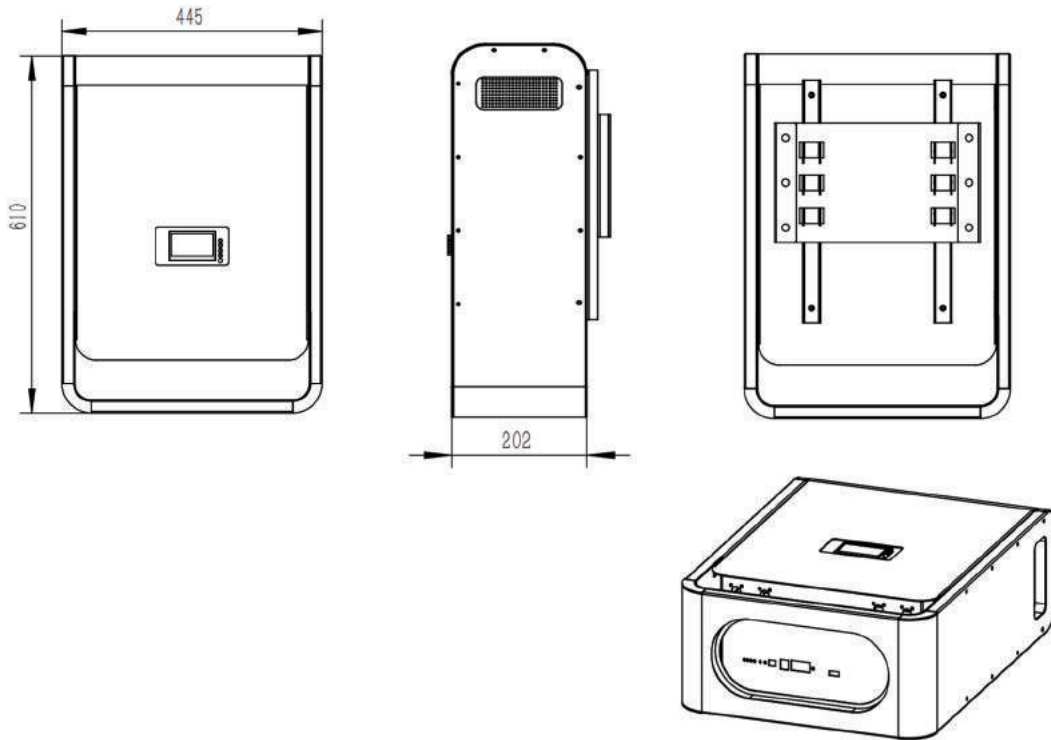

2.Equipment Interface Instruction

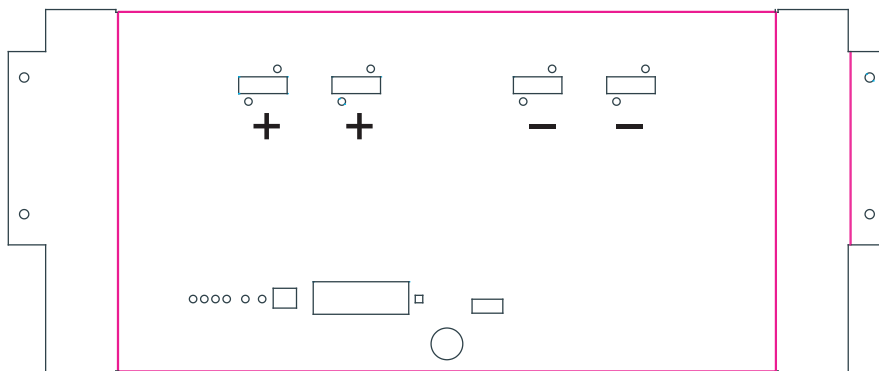

POWER SWITCH

Power Switch:to turn ON/OFF the whole battery BMS standby,power output ready.

SOC

SOC light:green LEDS to show the battery”s current capacity.

RUN

RUN light:green LED flashing to show the battery is running.

ALM

ALM light:red LED flashing to show the battery has alarm,and lighting to show the battery is under protection.

LED INDICATORS INSTRUCTIONS

State	Norminal/Warning/Protection	RUN	ALM	Power indicator LED				Instruction
		●	●	●	●	●	●	
Shut down	Dormancy	OFF	OFF	OFF	OFF	OFF	OFF	All OFF
Standby	Norminal	Flash 1	OFF	Follow module capacity				Standby
	Warning	Flash 1	Flash 3					Module at low voltage
Charge	Norminal	ON	OFF	Follow module capacity (Flash 2 at full capacity)				LED flash 2 at full capacity,ALM doesn't flash at overcharge warning
	Warning	ON	Flash 3					
	Overcharge protection	ON	OFF	ON	ON	ON	ON	If no grid supply,LED turn to standby
	Temperature,overcurrent, disabled protection	OFF	ON	OFF	OFF	OFF	OFF	Stop charging
Discharge	Norminal	Flash 3	OFF	Follow module capacity				
	Warning	Flash 3	Flash 3					
	Under voltage protection	OFF	OFF	OFF	OFF	OFF	OFF	Stop discharging
	Temperature,overcurrent, circuit,reverse connect, disabled protection	OFF	ON	OFF	OFF	OFF	OFF	Stop discharging
Disabled		OFF	ON	OFF	OFF	OFF	OFF	Stop charging discharging

NOTE: The flashing instructions,flash 1-light 0.25s/off 3.75 seconds;flash 2-0.5s light/0.5s off;flash 3-0.5s light/1.5s off;

RS232

RS232 Communication Terminal:(RJ11 port)follow RS232 protocol,for output batterues information.

CAN

CAN Communication Terminal:(RJ45 port)follow CAN protocol,for output batterues information.

RS485

RS485 Communication Terminal:(RJ45 port)follow RS485 protocol,for output batterues information.

Definition of RJ45 Port Pin

NO	RJ45 PIN
1、 8	RS485-B
2、 7	RS485-A
3、 6	GND
4	CAN-H
5	CAN-L



3.BMS Function

Protection and Alarm	Management and Monitor
Charge/Discharge End	Cell Balance
Charge Over Voltage	Intelligent Charge Model
Charge /Discharge Over Current	Charge/Discharge Current Limit
High/Low Temperature	Capacity/Retemtion Calculate
Short Circuit	Administrator Monitor
Power Cable Reverse	Operation Record

4.Schematic Diagram of Solution

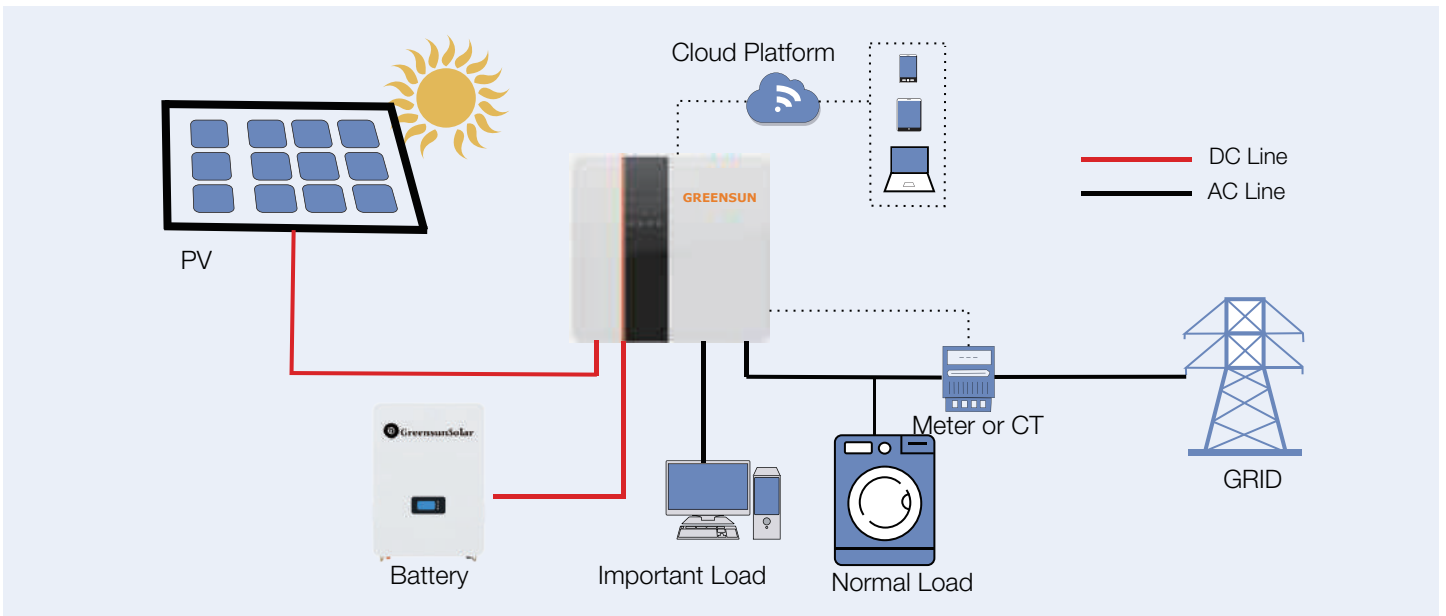

5.Cables

5.1 For battery module package:

Two power cables and one communication cable for each battery module package:



5.2 For battery system connects to inverter:
Two long power cables(current capacity 120A)and one communication cable
for each energy storage system:

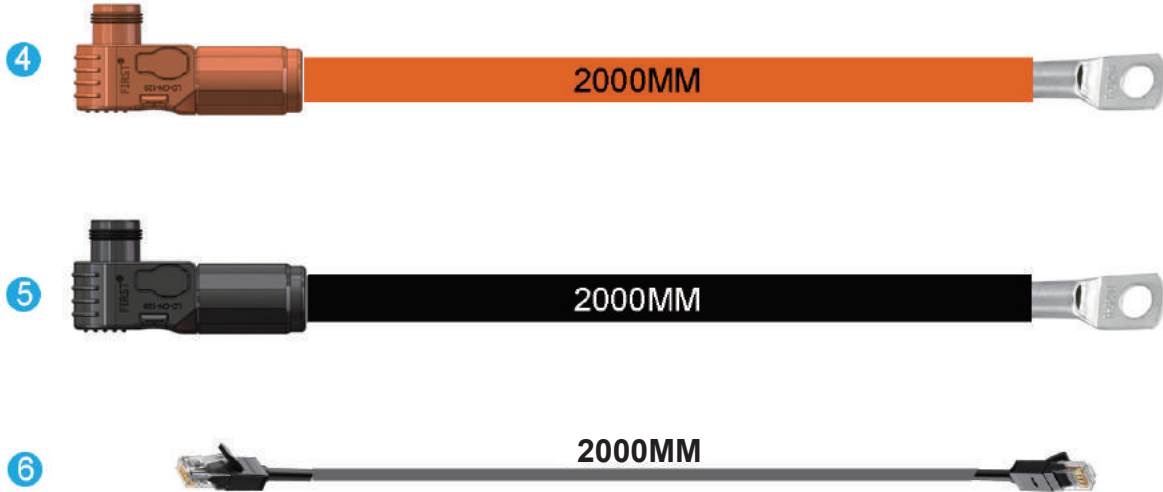

6.Installation

6.1 Put battery modules on the wall and connect the cables:

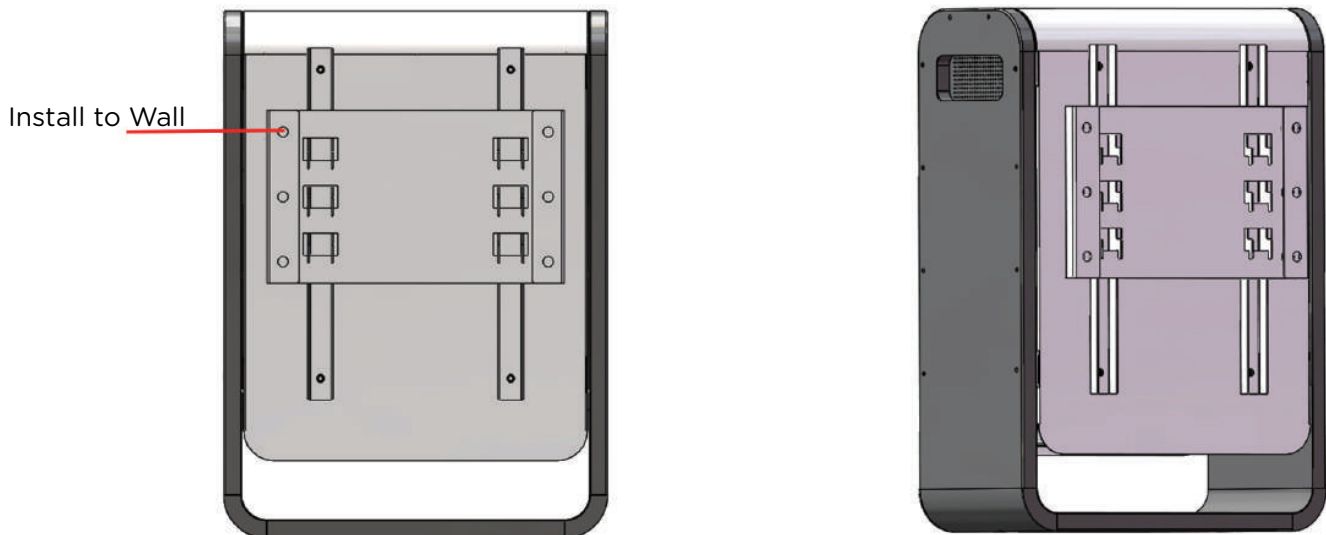

Note:If customer needs cabinet,please contact our salers

6.2 Power On

Double check all the power cable and communication cable.

(1) ON/OFF

Switch on all the battery modules and the green LED Light below will be on:

(2) Set ADD

Set ADD follow ADD instruction, pack 1 will be host, others are slaves.

7. Trouble shooting steps

7.1 Problem determination based on:

- 1) Whether the battery can be turned on .
- 2) If battery is turned on, check the red light is off. flashing or lighting;
- 3) If the red light is off, check whether the battery can be charged/discharged.

7.2 Preliminary determination steps:

- 1) Battery cannot be turned on, switch on the lights are all off lighting or flashing. If the battery external switch is ON, the RUN light is flashing, and the external power supply voltage is 51.2v or more, the battery still unable to turn on. please contact distributor.
 - 2) The battery can be turned on, but red light is lighting, and cannot be charged or discharged, red light is lighting, that means system is abnormal, please check values as following
 - 3) Temperature: Above 50°C or under -10°C, the battery could not work. Solution: to move battery to the normal operating temperature range between -10°C and 50°C.
 - 4) Current, If current is larger than 100A, battery protection will turn on.
Solution: Check whether current is too large or not, if it is, to change the settings on power supply side.
 - 5) High Voltage: If charging voltage above 28v, battery protection will turn on.
Solution: Check whether voltage is too high or not, if it is, to change the settings on power supply side.
 - 6) Low Voltage. When the battery discharges to 37.5v or less, battery protection will turn on.
Solution: Charge the battery for some time, the red light will turn off.
- Excluding the four points above, if the faulty is still cannot be located, turn off battery and repair.

7.3 The battery cannot be charged or discharged

1) Cannot be charged:

Disconnect the power cables, measure voltage on power side, if the voltage is 56.5-57, 6V, restart the battery, connect the power cable and try again, if still not work, turn off battery and contact distributor.

2) Unable to discharge.

Disconnect the power cables and measure voltage on battery side, if it is under 40V, please charge the battery, if voltage is above 51.2v and still cannot discharge, turn off battery and contact.

8. Emergency Situations

8.1 Leaking Batteries.

If the battery pack leaks electrolyte, avoid contact with the leaking liquid or gas. If one is exposed to the leaked substance, immediately perform the actions described below.

Inhalation: Evacuate the contaminated area, and seek medical attention

Contact with eyes: Rinse eyes with flowing water for 15 minutes, and seek medical attention.

Contact with skin: Wash the affected area thoroughly with soap and water, and seek medical attention

Ingestion: Induce vomiting, and seek medical attention.

8.2 Fire.

NO WATER! Only dry powder fire extinguisher can be used, if possible, move the battery pack to a safe area before it catches fire .

8.3 Wet Batteries.

If the battery pack is wet or submerged in water, do not let people access it, and then contact or an authorized dealer for technical support..

8.4 Damaged Batteries .

Damaged batteries are dangerous and must be handled with the utmost care. They are not fit for use and may pose a danger to people or property. If the battery pack seems to be damaged, pack it in its original/ container, and then return it to or an authorized dealer.

NOTE

Damaged batteries may leak electrolyte or produce flammable gas. If such damage occurs, please contact GREENSUN SOLAR.